

Letter: **ST-017-2019**

Date: December 05, 2019

To: Field Service Techs and Installers

Residential Variable Capacity Low Voltage Transformer Phasing

Subject:

All Residential Variable capacity air conditioning and heat pump models / matching gas furnace or air handling unit models.

Variable capacity systems utilize multiple control voltage transformers. The indoor equipment controls, room thermostat, and outdoor controls all communicate via an RS-485 bus. The RS-485 bus connects using a 3 wire connection scheme as shown below.

Data +	Non-inverted Signal	A+	GREEN
Data -	Inverted Signal	B-	WHITE
Common	24VAC Common / Ground		BLACK

The low voltage power common and the data ground are electrically the same point. They are physically connected on the controls. In all of our equipment, we bond the secondary 24VAC common side of the control transformer to equipment ground. Since the 24VAC common is used for communication ground, it is important that the wiring on both indoor and outdoor control transformers are connected the same. Figure 1 shows images of the control transformers used in both an indoor air handling unit (AHU), an outdoor (OD) variable capacity unit and a residential gas furnace.

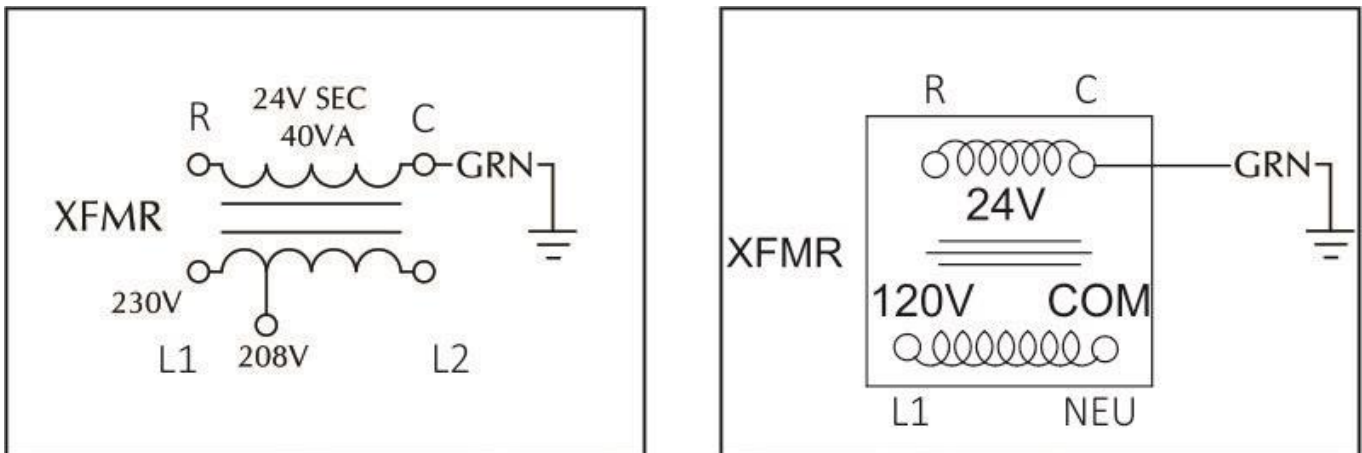

Figure 1 - Control Transformer Schematic

Outdoor line voltage input wiring is designated as L1 and L2. Indoor AHU line voltage input wiring is designated as L1 and L2. Indoor gas furnace line voltage input wiring is designated as L1 and NEUTRAL. The 24VAC (C) common wire should always be connected to the same side of the transformer that is bonded to equipment ground. Referencing figure 1, 24VAC (R) hot connection should be connected directly across to the left of the 24VAC “C” connection. Equipment input line voltage L1 should be connected directly below the 24 VAC “R” connection and line voltage L2 (OD and AHU) NEUTRAL (residential furnace) connection should be connected directly below the 24VAC “C” connection.

The outdoor variable capacity equipment control transformer comes factory wired as shown on the left side of figure 1. The matching air handling units developed for variable capacity outdoor equipment were based on existing AVC models. It was discovered that the line voltage wiring connected to the control voltage transformer was opposite of the outdoor section. Specifically, L1 and L2 were reversed – L2 was connected directly across from 24VAC “R.” To standardize for manufacturing, we changed all AHU L1 and L2 connections. L1 is now connected directly across from the 24VAC “R” connection just as the variable capacity outdoor sections.

All indoor residential furnace model control transformers are wired as shown below:

120V L1	BLACK
120V Neutral	WHITE
24V R	BROWN
24V C	BLUE

Only communicating variable speed blower model furnaces can be paired with variable capacity outdoor equipment. Applicable models are TM*V, (Y, C, L, T)P*C. TM*V models will not function if the low voltage wiring is reversed at the control transformer, however, the modulating furnace models ignore low voltage phasing. Shown in figure 2 are the low voltage transformer connections to the J10 8 pin plug on the furnace control board. Note that 24VAC GND and HOT are marked on the control board at the J10 connection. When the variable capacity equipment was developed, furnace blower motor profiles were slightly changed. One other change was the furnace wire harness. Specifically, the low voltage transformer wiring that connects to J10 was previously reversed meaning 24VAC “R” was connected to the GND connection and the 24VAC “C” was connected to the HOT connection. A model number generation change indicates the blower motor and wire harness change. Modulating models changed from **12C to **13C. Regardless, when commissioning a variable capacity outdoor unit an indoor transformer phasing test must be completed as part of the commissioning process.

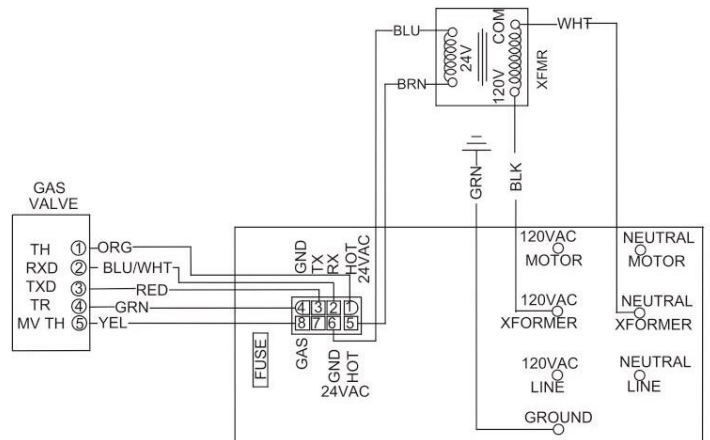

Figure 2 - Modulating Furnace Control Board Transformer Connections

Shown in figure 3 is a low voltage field control wiring diagram for a variable capacity system. The root cause for communicating fault errors are the result of **improper field installed** low voltage wiring. Common problems are accessories such as a float switch tied in series with the low voltage wiring or multiple wires under one screw terminal causing poor connections. As shown in the diagram, control wiring should be connected from each piece of equipment with no accessories. TM*V furnaces, AVV, and MVC air handler models have screw terminal connections to connect a float switch accessory. To connect a float switch to the above listed models, use the appropriate control board connections provided. To wire a float switch into a modulating furnace, the 24VAC R wire leaving the control transformer can be opened between the control transformer and the furnace control board.

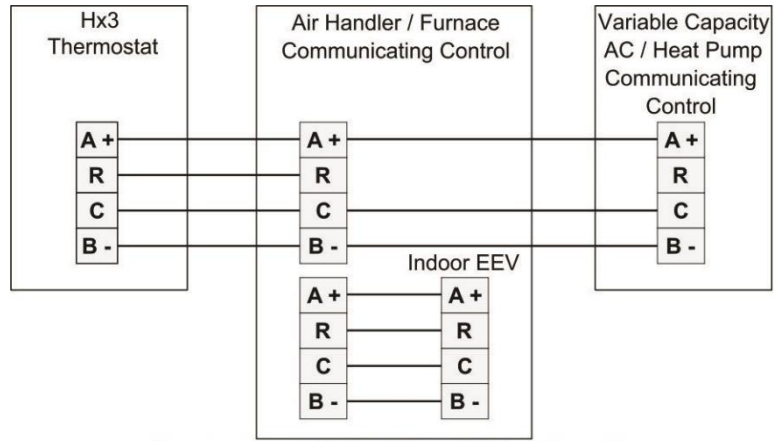

Figure 3 - Communicating Control Wiring Schematic

To test low voltage transformer phasing, there must be an indoor 24VAC "R" wire at the outdoor unit. The indoor "R" wire is **not** to be connected to the outdoor unit. The wire will be used as a test point for a voltmeter lead. Shown in figure 4 is a diagram illustrating the 24VAC indoor "R" wire with a cap on the wire at the outdoor unit.

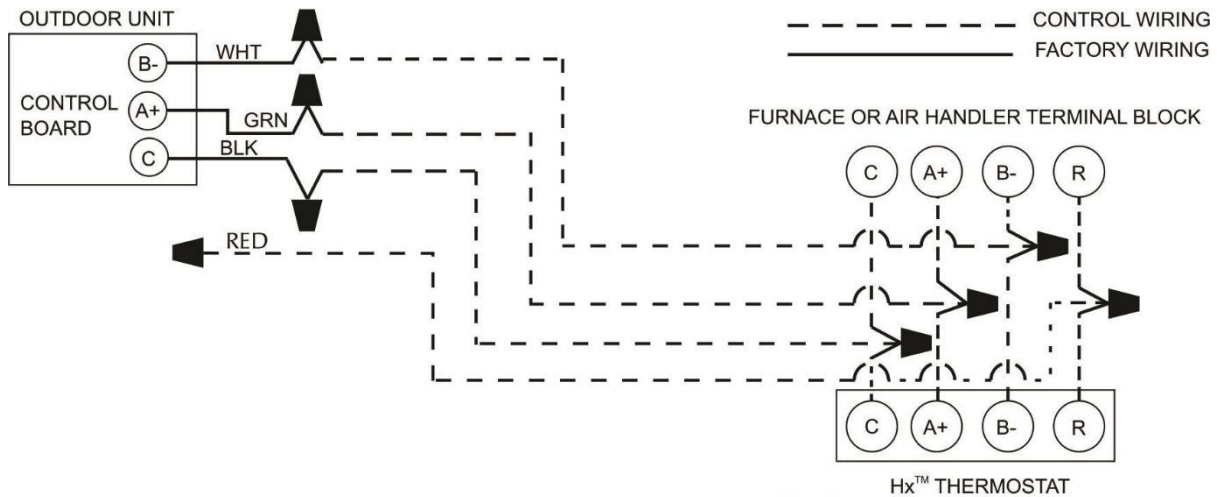

Figure 4 - Temporary 24VAC "R" Wiring

For a modulating variable speed furnace, test AC voltage from the furnace control board L1 to thermostat R connection as shown in figure 5. If indoor wiring is correct, the displayed reading should be line voltage minus low voltage – approximately 96 volts AC. If indoor wiring is incorrect, the displayed reading should be line voltage plus low voltage – approximately 144 volts AC. **If incorrect**, reverse the two low voltage wires on the furnace control transformer. See test point locations shown in figure 5.

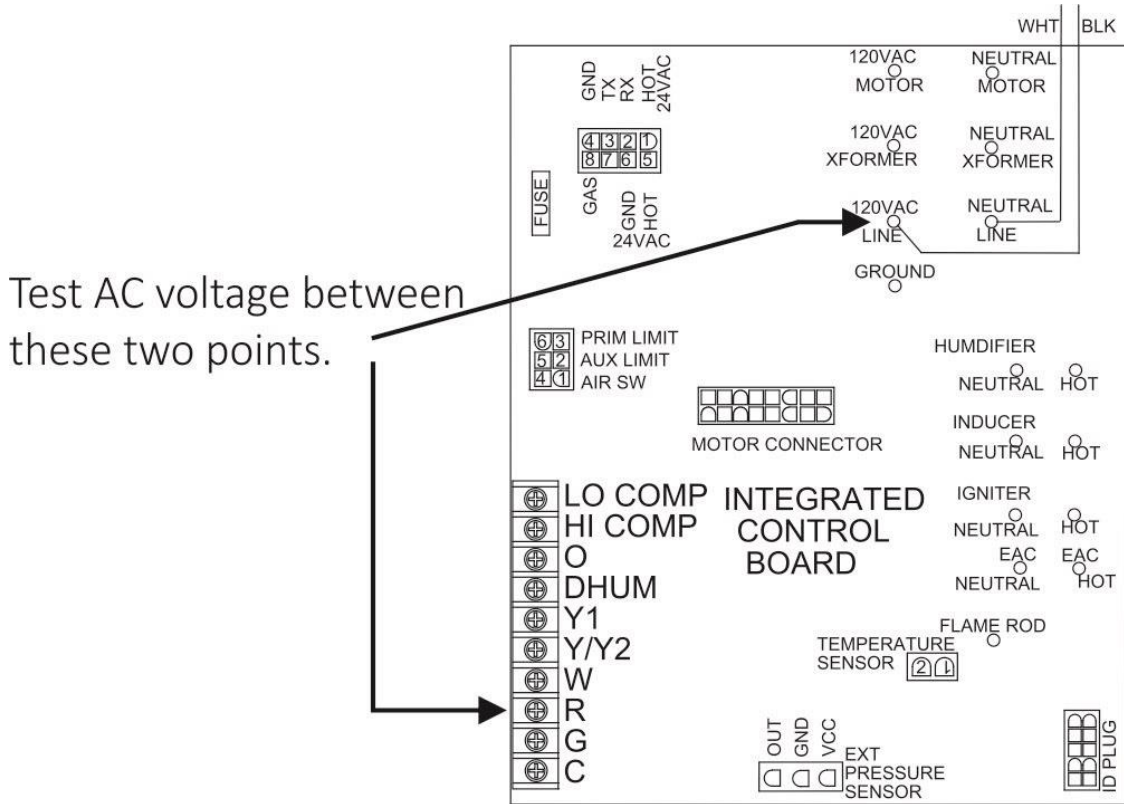

Figure 5 - Modulating Furnace Control Board Test Points

For a two stage variable speed furnace, test AC voltage from the furnace control board L1 to thermostat R connection as shown in figure 6. If indoor wiring is correct, the displayed reading should be line voltage minus low voltage – approximately 96 volts AC. If indoor wiring is incorrect, the displayed reading should be line voltage plus low voltage – approximately 144 volts AC. **If incorrect**, reverse the two low voltage wires on the furnace control transformer. See test point locations shown in figure 6.

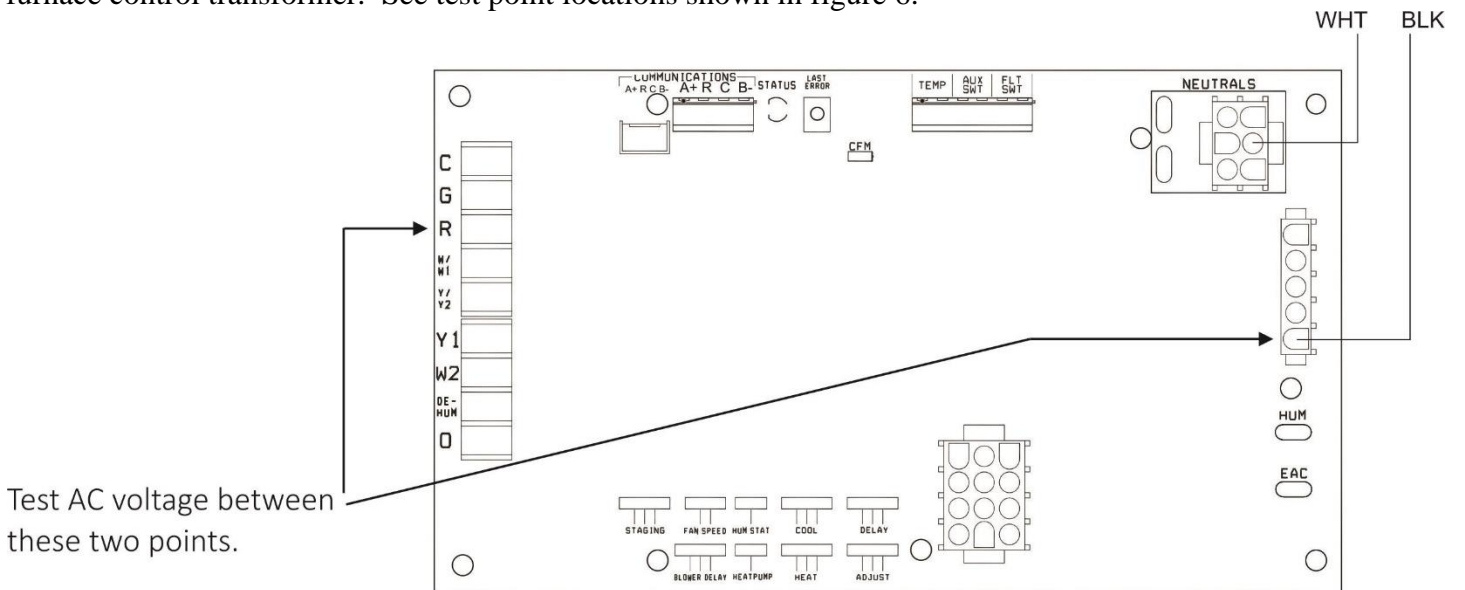

Figure 6 - Two Stage Variable Speed Furnace Control Board Test Points

As stated above and shown on the control transformers in figure 1, 24VAC “R” is located directly across from line voltage terminal we are designating as L1. Respectively, 24VAC “C” is located directly across from line voltage terminal we are designating as L2. When checking a control transformer supplied by 230-240 VAC and no other wiring problem is present, the designated L1 to 24 VAC “R” connection will always read approximately 96 volts AC and the designated L2 to 24 VAC “C” connection will always read approximately 144 volts AC regardless if you were to physically swap the L1 and L2 wires connected to the control transformer.

NOTICE

If line voltage power supply is 208 Volts and the 208V transformer tap is being used as required, L1 to R ~ 100 VAC and L1 to C ~ 125 VAC.

Due to this fact, we must make sure that the home (or building) supply power connected to L1 on the indoor equipment is the same phase or “leg” of power feeding the outdoor equipment L1 connection, L2 respectively. On AVV and MVC model air handling units, confirm transformer wiring is as shown in the diagram in figure 7. If not, correct as necessary. L1 (BLK) should be directly across from 24VAC “R” (ORG). If equipment input voltage is 208 VAC, the L1 transformer connection **MUST** be moved from the 240VAC tap to the 208VAC tap on both indoor and outdoor sections.

Figure 8 is a wiring diagram of a variable capacity heat pump outdoor unit. Starting at the terminal block (TB) where the field wiring is connected to, confirm all unit wiring is per the unit wiring diagram. Unit wiring attached to L1 at TB should include 3 black wires. Unit wiring attached to L2 at TB should include two white wires and one brown wire. Confirm L1 wires connect to L1 on the inverter drive and the 208 or 230 VAC control transformer tap. Confirm 24VAC Red wire is connected directly across from the black L1 wire on the control transformer and that the 24VAC Red wire is connected to the correct place on the VS control board as shown in the diagram.

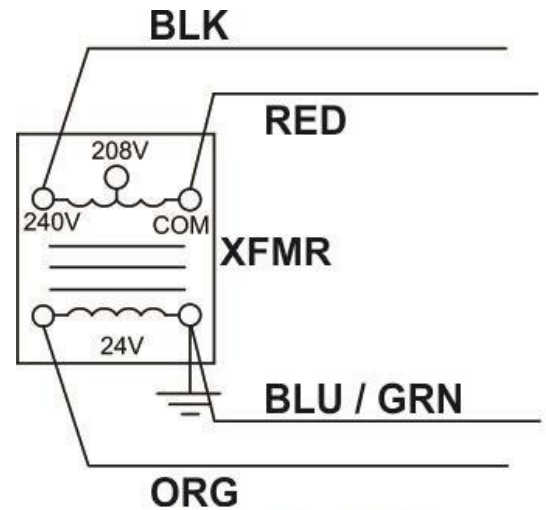

**Figure 7 - AHU
Transformer Schematic**

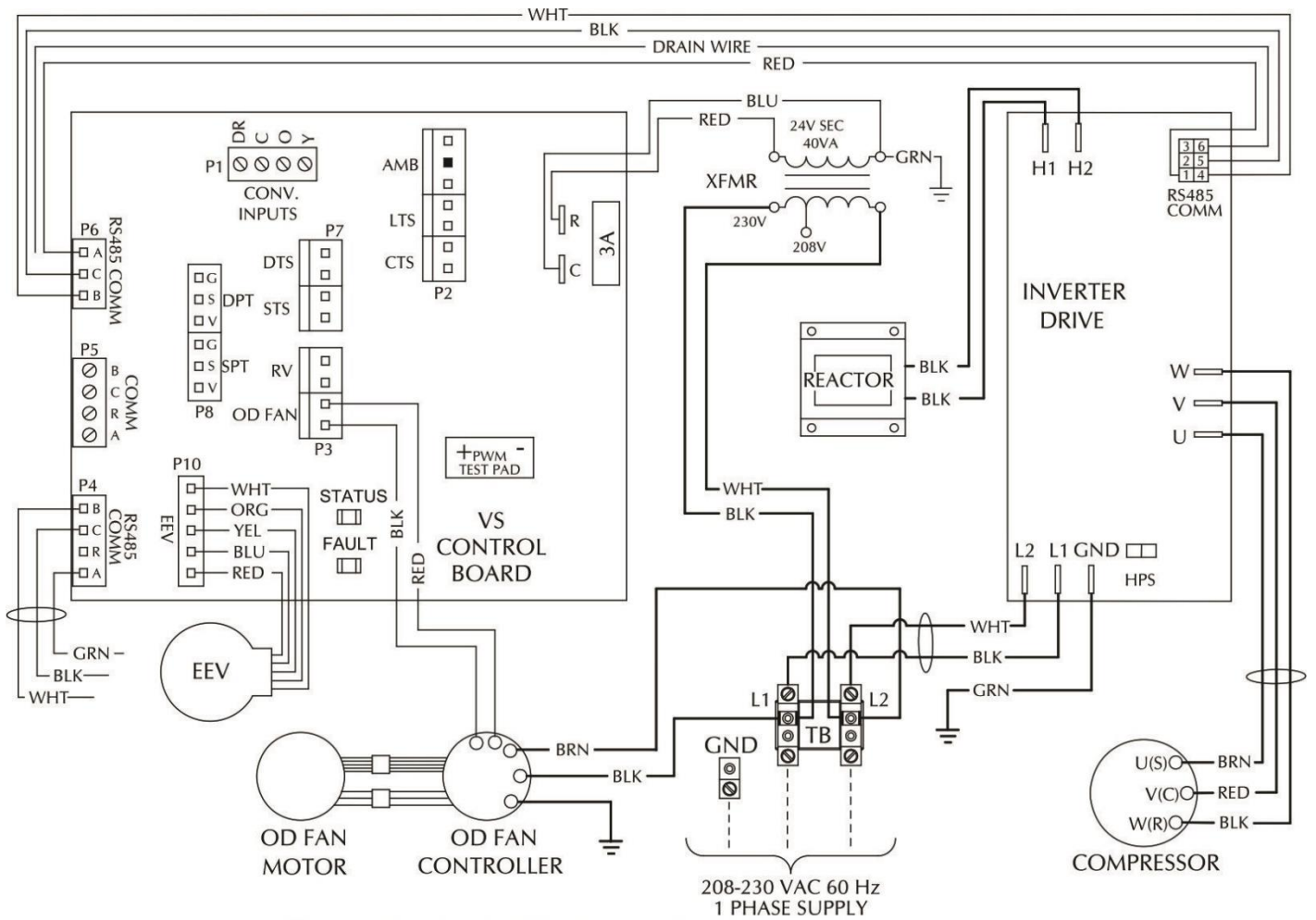

Figure 8 - Variable Capacity Wiring Diagram

Figure 9 is a wiring diagram of a variable capacity heat pump outdoor unit showing 6 different test points to read volts AC. Outdoor unit **line voltage** will be tested at TB. Outdoor unit **low voltage** will be tested on the VS Control Board **P5** connection. Indoor **low voltage** will be tested at the field wiring termination/connections that should be located in the outdoor unit low voltage field wiring box at the bottom of the outdoor unit control box.

- | | | |
|--|-------|----------------------|
| 1. Outdoor L1 to outdoor L2 ~ 208 / 240 VAC: | _____ | |
| 2. Outdoor R to outdoor C ~ 24 VAC: | _____ | |
| 3. Indoor R to indoor C ~ 24 VAC: | _____ | |
| 4. Outdoor L1 to outdoor R ~ 96 VAC: | _____ | **SEE NOTICE BELOW** |
| 5. Outdoor L1 to outdoor C ~ 144 VAC: | _____ | **SEE NOTICE BELOW** |
| 6. Outdoor L1 to indoor R ~ 96 VAC: | _____ | **SEE NOTICE BELOW** |

NOTICE

If line voltage power supply is 208 Volts and the 208V transformer tap is being used as required, L1 to R ~ 100 VAC and L1 to C ~ 125 VAC.

If all outdoor equipment wiring is correct per all diagrams above, there is a 50/50 chance that the reading taken in step 6 above will be approximately 96 VAC. If L1 and L2 outdoors are opposite of L1 and L2 indoors (AHU) or L1 and NEUTRAL indoors (gas furnace), the reading found in step 6 will be approximately 144 VAC. If approximately 144 VAC is found, **DISCONNECT** power from outdoor unit. Reverse the **FIELD** wiring connections on the outdoor unit (**TB**) terminal block. Re-apply power and re-take step 6 reading. If approximately 96 VAC is not found, other wiring or grounding problems exist. Call residential technical services for further support.

NOTICE

If line voltage power supply is 208 Volts and the 208V transformer tap is being used as required, L1 to R ~ 100 VAC and L1 to C ~ 125 VAC.

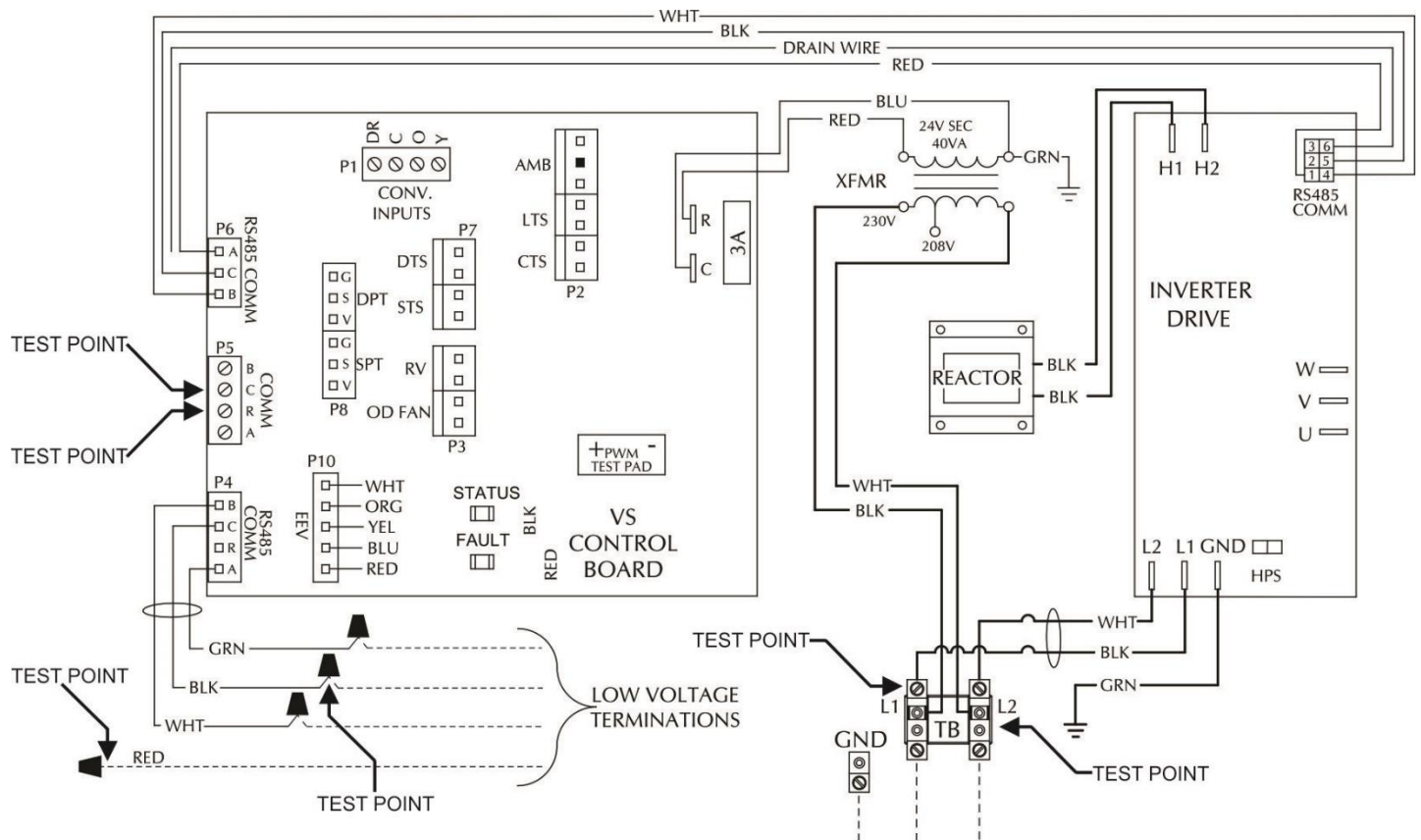

Figure 9 - Variable Capacity Test Point Locations

Variable capacity equipment was designed, tested and listed for operation in residential comfort cooling/heating applications supplied with 208 – 230 VAC single phase power. Equipment can be applied to buildings utilizing 208 – 230 VAC three phase power, however the two phases or “legs” of power supplying the outdoor section must be the same ones supplying the indoor section. Figures 10 – 13 show several diagrams illustrating correct line voltage power wiring to both indoor and outdoor sections when equipment is installed and connected to 208 – 230 VAC 3 phase power. Notice that whatever phase is connected to the outdoor L1 connection, the same phase is connected to the indoor L1 connection. If the building power supply is a three phase four wire delta service, make sure that the high leg or “wild leg” is not connected to the indoor section if a gas furnace is being used. The “B” phase (L2 in our examples) is the high leg. If the indoor section is an air handling unit, the high

leg may be utilized but the same rule applies – the two phases of power supplying the outdoor section must be the same ones supplying the indoor section.

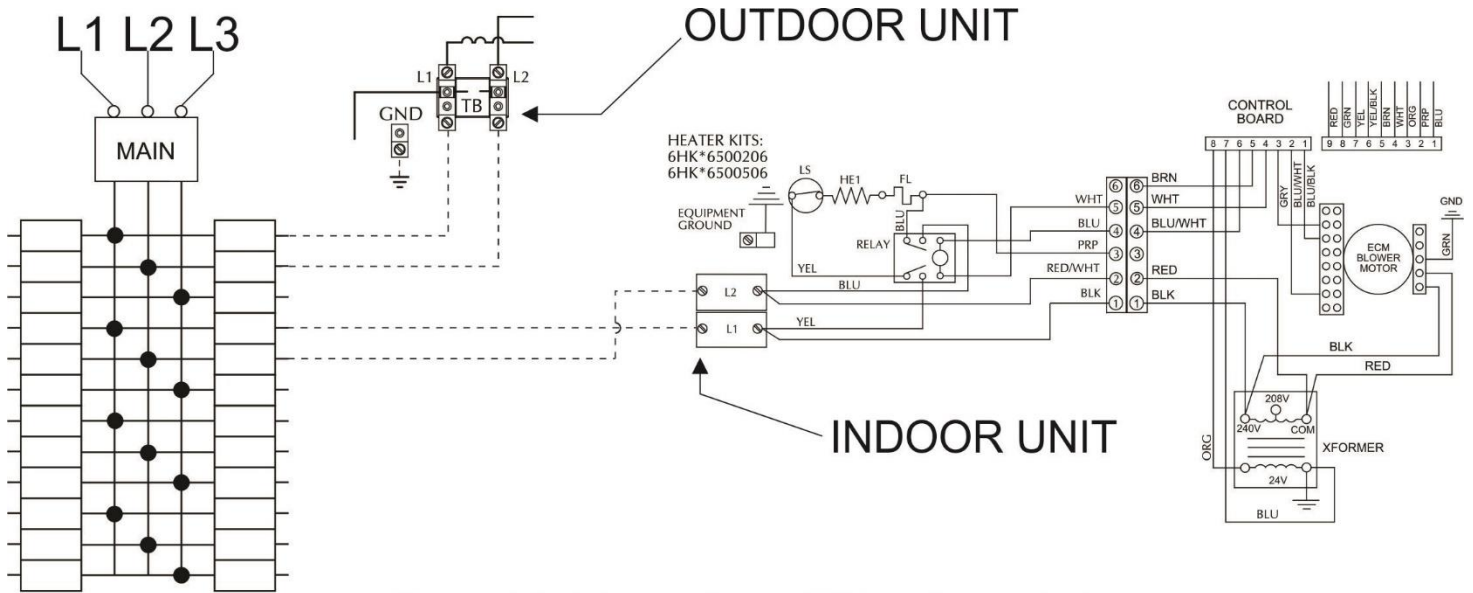

Figure 10 - Three Phase Wiring Example 1

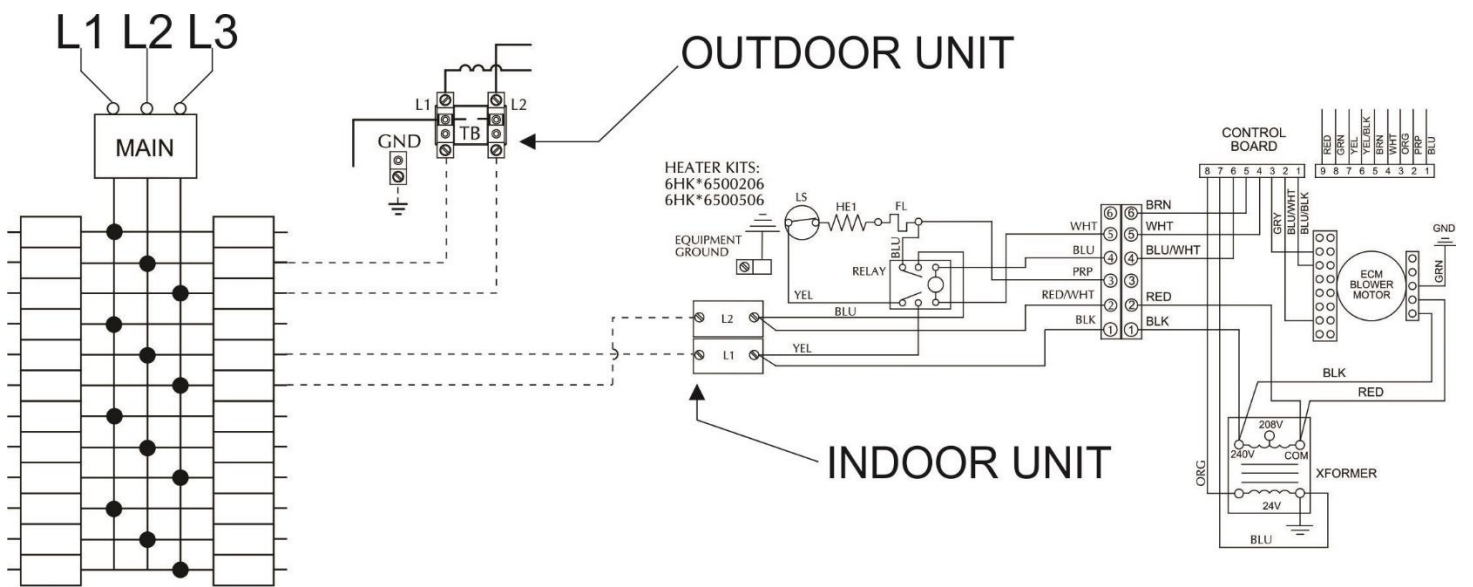

Figure 11 - Three Phase Wiring Example 2

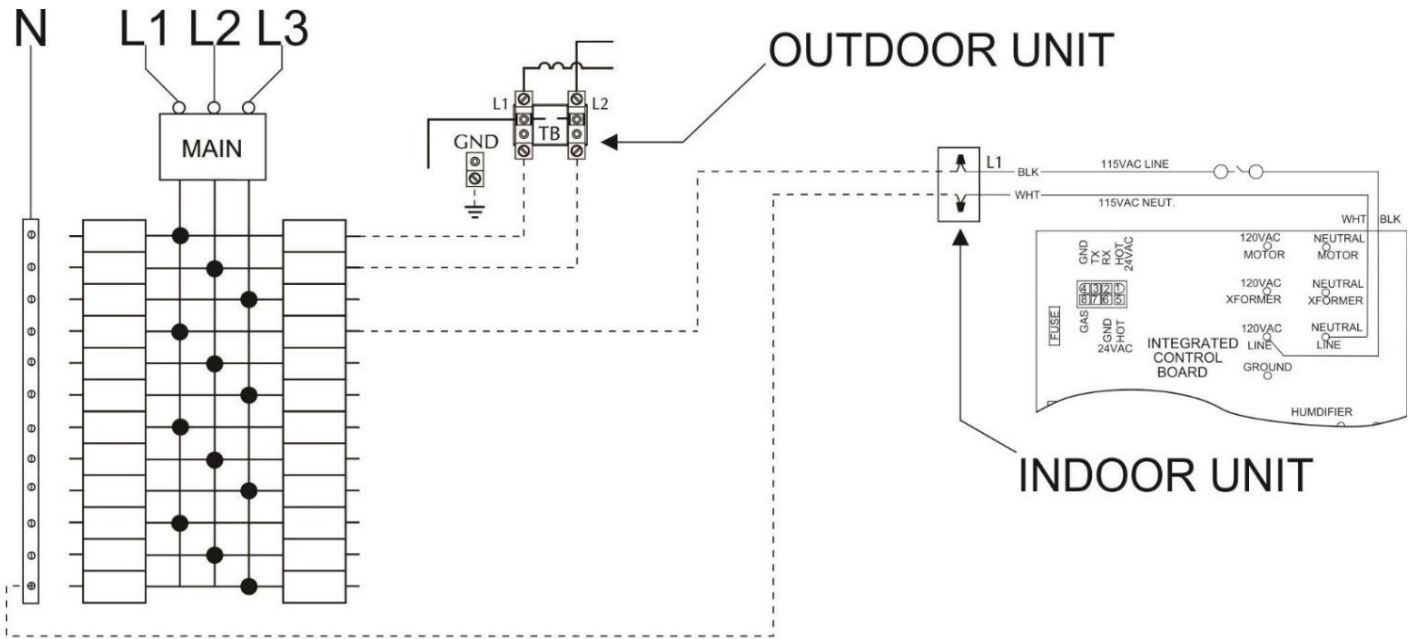

Figure 12 - Three Phase Wiring Example 3

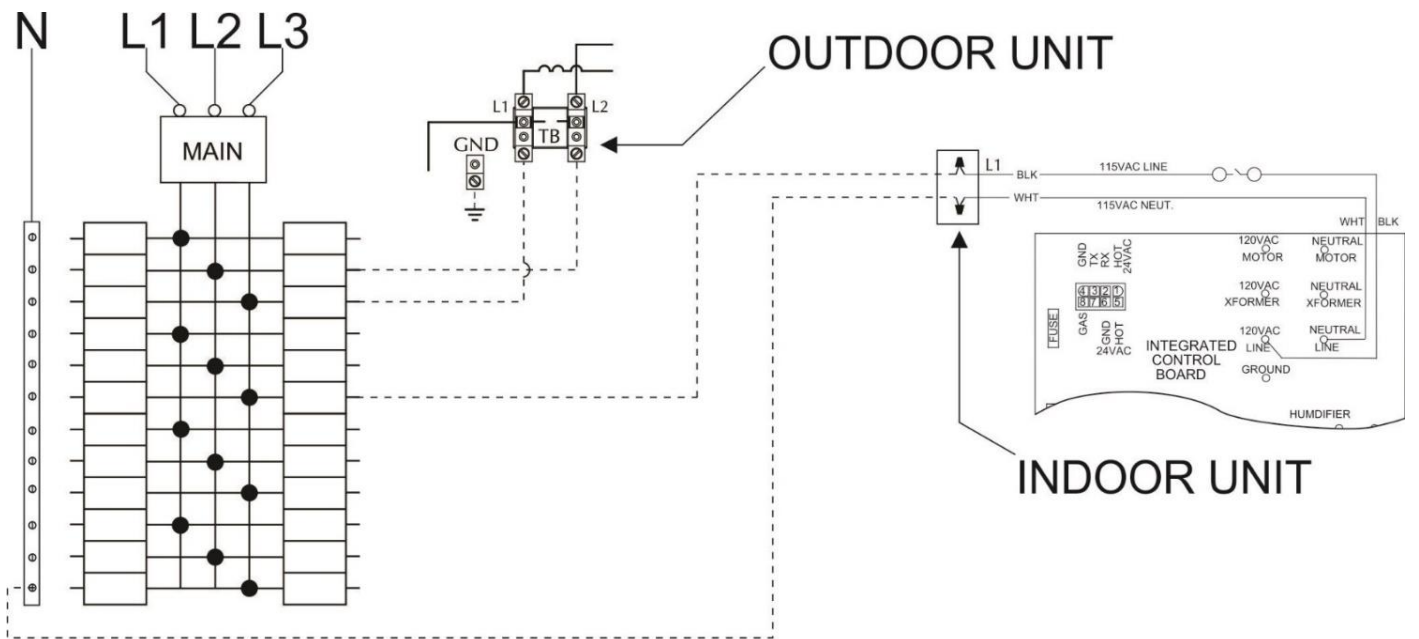

Figure 13 - Three Phase Wiring Example 4