

Revision Date: 12/13/2024

Subject: E496 Error Code

Models: DVM, CHILLER

Title: DC Link Voltage Sensor Error in Fan PCB

Issue

DC Link Voltage Sensor Error in Fan PCB – DC Link Voltage error
(Determined by Fan PCB DC Link Voltage Sensor)

Always refer to wiring diagram for specific model. Use the link below for a model search and see the technical data book for the wiring diagram.

<https://www.samsunghvac.com/downloads>

Troubleshooting Steps

230V Heat Pump and Heat Recovery Diagnostics

1. Check the Incoming Voltage (208/230Vac \pm 10%)
2. Power the unit OFF for 15-20 minutes before continuing to step 3
3. Check Fuses on EMI PCB
4. Remove the wires on the Reactor coil and ohm the Reactor (resistance value should be less than 5 ohms, open to ground on each leg)
5. Disconnect DC Link Voltage connector from the FAN PCB (leave connected to Inverter PCB)
6. Move the disconnected end of the DC Link Voltage harness to a safe location so voltage can be tested from White to Yellow when power is applied.
7. Restore power to unit and check for proper DC Link Voltage

DC Link Voltage is sent from the Inverter PCB to the Fan PCB for both 230 & 460V Heat Pumps)

DC Link Voltage Connector (Yellow to White Wire)

To calculate the DC Link Voltage, multiple incoming AC power times 1.41

Example:

Incoming Voltage x 1.41 = DC Link Voltage

230Vac x 1.41 = 324.3 Vdc (DC Link Voltage)

460Vac x 1.41 = 648.6 Vdc (DC Link Voltage)

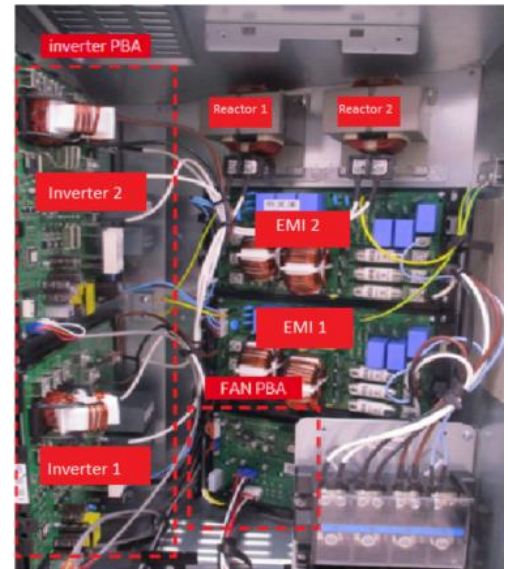

RESULTS

- If incoming voltage is incorrect, correct supply voltage (208/230 Vac \pm 10%)
- If EMI PCB has an open fuse, replace the EMI PCB
- If the Reactor is open or short to ground, replace the Reactor
- If DC Link Voltage is accurate, replace Fan PCB (DC Link Voltage sensor in Fan PCB is faulty)
- If supply power, EMI Fuses, and Reactor test within range, but DC Link Voltage is under 150Vdc, replace Inverter 1 and Fan PCB



**** Before reconnecting wire harnesses or DC Link Voltage, leave the unit powered OFF for 15 – 20 min****

460V Heat Pump and Heat Recovery Diagnostics (Reference Pictures on Page 1)

1. Check Incoming Voltage (460Vac \pm 10%)
2. Check the Voltage at the Transformer (Primary 460V, Secondary 230V)

The Transformer is in the lower left side of the unit near compressor 1. It is not located in the control board cabinet.

3. Power the unit OFF for 15-20 minutes before continuing to step 4
4. Check the fuses on the EMI PCB
5. Remove the wires on the Reactor coil and ohm the Reactor (resistance value should be less than 5 ohms, open to ground on each leg)
6. Disconnect DC Link Voltage connector from the FAN PCB (leave connected to Inverter PCB)
7. Move the disconnected end of the DC Link Voltage harness to a safe location so voltage can be tested from White to Yellow when power is applied.
8. Restore power to unit and check for proper DC Link Voltage

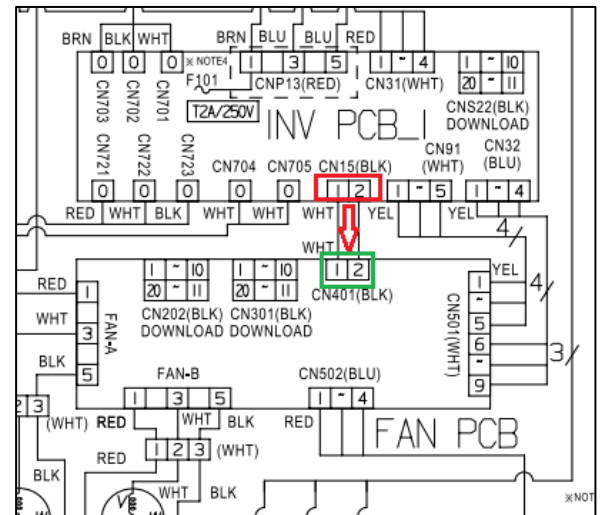

460V to 230V Transformer

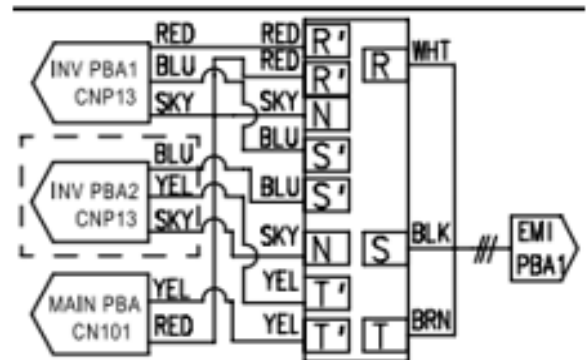

RESULTS

- If incoming voltage is incorrect, correct supply voltage (460Vac \pm 10%)
- If EMI PCB has an open fuse, replace the EMI PCB
- If the Reactor is open or short to ground, replace the Reactor
- If DC Link Voltage is accurate, replace Fan PCB (DC Link Voltage sensor in Fan PCB is faulty)
- If supply power, EMI Fuses, and Reactor test within range, but DC Link Voltage is under 150Vdc, replace Inverter 1 and Fan PCB



**** Before reconnecting wire harnesses or DC Link Voltage, leave the unit powered OFF for 15 – 20 min****